

# KENWOOD

## KDC-115S

**Take the time to read through this instruction manual.**

**Familiarity with installation and operation procedures will help you obtain the best performance from your new CD-receiver.**

### **For your records**

Record the serial number, found on the back of the unit, in the spaces designated on the warranty card, and in the space provided below. Refer to the model and serial numbers whenever you call upon your KENWOOD dealer for information or service on the product.

Model KDC-115S

Serial number \_\_\_\_\_

CD-RECEIVER

## **INSTRUCTION MANUAL**

AMPLI-TUNER-LECTEUR DE CD

## **MODE D'EMPLOI**

REPRODUCTOR DE DISCOS COMPACTOS RECEPTOR DE FM/AM

## **MANUAL DE INSTRUCCIONES**

RECEPTOR DE CD

## **MANUAL DE INSTRUÇÕES**

KENWOOD CORPORATION



©B64-1543-00 (KW)

## Contents

### Before use

▲Warning .....	2
Safety precautions .....	3
Handling Compact discs .....	5

### General features

Power .....	6
Switching Modes .....	6
Volume .....	6
Attenuator .....	7
Loudness .....	7
Audio Control Setting .....	7
ec4/dB (Sound Coordinate) .....	8
Clock display .....	8
Adjusting Time .....	8

### Tuner features

Tuning .....	9
Station Preset Memory .....	10
Auto Memory Entry .....	10
Clean Reception System Circuit (CRSC) .....	10

### CD player features

Playing CDs .....	11
Fast Forwarding and Reversing Disc Play .....	11
Track Search .....	12
Track Repeat .....	12
Track Scan .....	12
Random Play .....	12

### Installation

Accessories .....	13
Installation Procedure .....	13
Connecting Wires to Terminals .....	14
Installation .....	15
Installing in Japanese-Made Cars .....	15
Removing the hard rubber frame .....	16
Removing the Unit .....	16

### Troubleshooting guide ..... 17

### Specifications ..... 19

## ▲Warning

### ▲CAUTION

Use of controls or adjustments or performance of procedures other than those specified herein may result in hazardous radiation exposure.

In compliance with Federal Regulations, following are reproductions of labels on, or inside the product relating to laser product safety.

KENWOOD CORPORATION  
2967-3, ISHIKAWA-CHO,  
HACHIOJI-SHI  
TOKYO, JAPAN

KENWOOD CORP. CERTIFIES THIS EQUIPMENT  
CONFORMS TO DHHS REGULATIONS NO.21 CFR  
1040. 10, CHAPTER 1, SUBCHAPTER J.

Location : Bottom Panel

### FCC WARNING

This equipment may generate or use radio frequency energy. Changes or modifications to this equipment may cause harmful interference unless the modifications are expressly approved in the instruction manual. The user could lose the authority to operate this equipment if an unauthorized change or modification is made.

## Safety precautions

### NOTE

This equipment has been tested and found to comply with the limits for a Class B digital device, pursuant to Part 15 of the FCC Rules. These limits are designed to provide reasonable protection against harmful interference in a residential installation. This equipment may cause harmful interference to radio communications, if it is not installed and used in accordance with the instructions. However, there is no guarantee that interference will not occur in a particular installation. If this equipment does cause harmful interference to radio or television reception, which can be determined by turning the equipment off and on, the user is encouraged to try to correct the interference by one or more of the following measures:

- Reorient or relocate the receiving antenna.
- Increase the separation between the equipment and receiver.
- Connect the equipment into an outlet on a circuit different from that to which the receiver is connected.
- Consult the dealer or an experienced radio/TV technician for help.

### NOTE

This Class B digital apparatus complies with Canadian ICES-003.

### ▲WARNING

**To prevent injury or fire, take the following precautions:**

- Insert the unit all the way in until it is fully locked in place. Otherwise it may fall out of place when jolted.
- When extending the ignition, battery, or ground wires, make sure to use automotive-grade wires or other wires with a 0.75mm<sup>2</sup> (AWG18) or more to prevent wire deterioration and damage to the wire coating.
- To prevent a short circuit, never put or leave any metallic objects (such as coins or metal tools) inside the unit.
- If the unit starts to emit smoke or strange smells, turn off the power immediately and consult your Kenwood dealer.
- Be careful not to drop the unit or subject it to strong shock.  
The unit may break or crack because it contains glass parts.
- Do not touch the liquid crystal fluid if the LCD is damaged or broken due to shock. The liquid crystal fluid may be dangerous to your health or even fatal.  
If the liquid crystal fluid from the LCD contacts your body or clothing, wash it off with soap immediately.

### ▲CAUTION

**To prevent damage to the machine, take the following precautions:**

- Make sure to ground the unit to a negative 12V DC power supply.
- Do not open the top or bottom covers of the unit.
- Do not install the unit in a spot exposed to direct sunlight or excessive heat or humidity. Also avoid places with too much dust or the possibility of water splashing.
- Do not subject the faceplate to excessive shock, as it is a piece of precision equipment.
- When replacing a fuse, only use a new one with the prescribed rating. Using a fuse with the wrong rating may cause your unit to malfunction.
- To prevent a short circuit when replacing a fuse, first disconnect the wiring harness.
- Do not use your own screws. Use only the screws provided. If you use the wrong screws, you could damage the unit.

## Safety precautions

### NOTE

- If you experience problems during installation, consult your Kenwood dealer.
- If the unit does not seem to be working right, try pressing the reset button first. If that does not solve the problem, consult your Kenwood dealer.

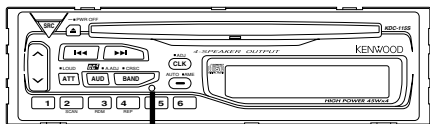

Reset button

- Characters in the LCD may become difficult to read in temperatures below 41 °F (5 °C).
- The illustrations of the display and the panel appearing in this manual are examples used to explain more clearly how the controls are used. Therefore, what appears on the display in the illustrations may differ from what appears on the display on the actual equipment, and some of the illustrations on the display may represent something impossible in actual operation.

### Cleaning the Unit

If the front panel gets dirty, turn off the power and wipe the panel with a dry silicon cloth or soft cloth.

### CAUTION

Do not wipe the panel with a hard cloth or a cloth dampened by volatile solvents such as paint thinner and alcohol. They can scratch the surface of the panel and/or cause the indicator letters to peel off.

### Cleaning the CD Slot

As dust tends to accumulate in the CD slot, clean it every once in a while. Your CDs can get scratched if you put them in a dusty CD slot.

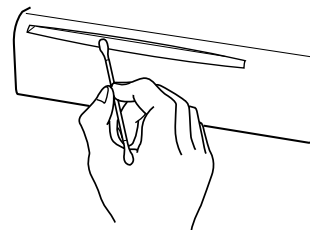

### Lens Fogging

Right after you turn on the car heater in cold weather, dew or condensation may form on the lens in the CD player of the unit. Called lens fogging, CDs may be impossible to play. In such a situation, remove the disc and wait for the condensation to evaporate. If the unit still does not operate normally after a while, consult your Kenwood dealer.

### CAUTION

#### **Do Not Load 3-in. CDs in the CD slot**

If you try to load a 3 in. CD with its adapter into the unit, the adapter might separate from the CD and damage the unit.

## Handling Compact discs

**Playing a CD that is dirty, scratched or warped can cause the sound to skip and the unit to operate incorrectly, resulting in worsened sound quality. Take the following precautions to prevent your CDs from getting scratched or damaged.**

### Handling CDs

- Do not touch the recorded side of the CD (the side opposite the label) when holding it.

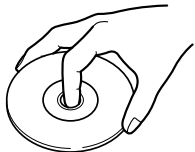

- Do not stick tape on either side of the CD.

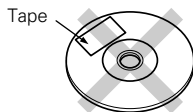

### Storing CDs

- Do not store CDs in areas exposed to direct sunlight (such as a car seat or the dashboard) or other hot places.
- Remove CDs from the unit when not listening to them for a while, and put them back in their cases. Do not pile up CDs that are removed from their cases or prop them against something.

### Cleaning CDs

If a CD has gotten dirty, wipe it off gently using a commercially available cleaning cloth or a soft cotton cloth, starting from the center of the disc and moving outward. Do not clean CDs with conventional record cleaners, anti-static formulas, or chemicals such as paint thinner or benzene.

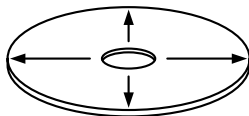

### Checking New CDs for Burrs

When playing a new CD for the first time, check that there are not any burrs stuck to the perimeter of the disc or in the central hole. CDs with burrs stuck on them may not load properly or may skip while playing. Remove burrs using a ballpoint pen or a similar utensil.

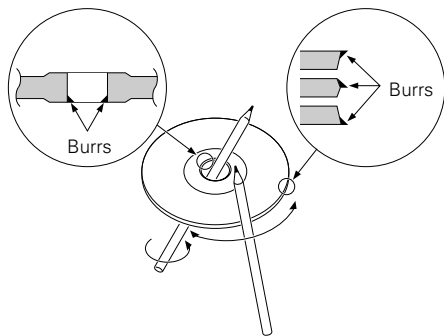

### Do Not Load CD Accessories

Do not use commercially available CD accessories that can be loaded into the CD slot, such as stabilizers, protective sheets, or CD cleaning discs, since they can cause the unit to malfunction.

### Removing the CD

Only remove the CD from the machine in a horizontal direction, holding it flat. You may damage the surface of the CD if you try pulling it down as it ejects.

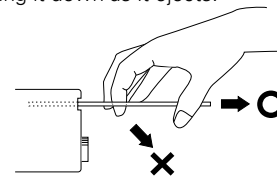

### Do Not Use Special Shape CDs

- Be sure to use round shape CDs only for this unit and do not use any special shape CDs. Use of special shape CDs may cause the unit to malfunction.



- Be sure to use CDs with disc mark  only for this unit.

### Do Not Use CDs with Sticker on the Labeled Side

Do not use the CD with the label sticker stuck on it. Using such a CD may cause the CD to be deformed and the sticker to peel off, resulting in malfunction of the unit.



Press the  $\wedge$  button to turn up the volume.

#### **Decreasing Volume:**

Press the  $\vee$  button to turn down the volume.

### **Attenuator**

This function allows you to turn down the volume quickly.

#### **Turning Attenuator On/Off:**

Press the ATT button to switch the attenuator on and off.

When the attenuator is on, the ATT indicator blinks.

When the attenuator is off, the volume returns to the original level.

#### **NOTE**

Turning the volume up, or turning it all the way down deactivates the attenuator function.

### **Loudness**

This function amplifies low and high tones when the volume is turned down.

The LOUD indicator lights up when the loudness function is on.

#### **Turning Loudness On/Off:**

Press the LOUD button for at least one second to switch the loudness on and off.

### **Audio Control Setting**

Adjust various parameters of sound quality.

- 1 Press the AUD button for at least one second to enter the control mode.

## **2 Selecting mode**

Press the BAND button.

Each time the button is pressed, the adjustment mode will change.

Please refer to the following for the contents of the adjustment modes.

#### **NOTE** Source tone memory

Each source ( FM, AM and CD ) has its own memory in which to store the bass and treble tone settings.

The settings made for a particular source are recalled automatically whenever you use that source ( for example, FM mode uses the tone settings made for FM, AM for AM, etc.).

## **3 Adjust each mode**

Press the  $\lll/\ggg$  button.

Please refer to the following for the adjusting values.

- 4 Press the AUD button to end the control mode.

#### **"BAS" : Adjust the bass level.**

Setting values: - 8 - + 8

#### **"TRE" : Adjust the treble level.**

Setting values: - 8 - + 8

#### **"BL" : Adjust the balance level.**

Setting values: Left 15 - Right 15

## General features

### "FD" : Adjust the fader level.

Setting values: Front 15 – Rear 15

### ec4/dB (Sound Coordinate)

You can recall the best audio setting preset for different types of the music.

- 1 Press the AUD button to enter the Sound Coordinate mode.
- 2 Press a preset button (#1-5).  
The preset settings of the bass and treble tones are recalled.  
#1: Flat  
#2: Rock  
#3: Pops/Top 40  
#4: Jazz  
#5: Easy
- 3 Press the AUD button to end the sound coordinate mode.

#### NOTE

You can call the following settings with this function; bass center frequency, bass level, bass quality factor, bass extension, treble center frequency, and treble level setting.

### Clock display

#### Turning clock display On/Off:

Each time you press the CLK button, the display switches between the clock and each mode display.

### Adjusting Time

Adjust the time.

- 1 When the time is not displayed, first press the CLK button to display the time.
- 2 Press the CLK button for at least two seconds to enter the clock adjustment mode. The time display will blink.
- 3
  - Adjusting the hours  
Press the BAND button to advance the hours.
  - Adjusting the minutes  
Press the ►► button to advance the minutes, or press the ◀◀ button to make the minutes go back.
- 4 Press the CLK button to end the clock adjustment mode.



## Tuner features

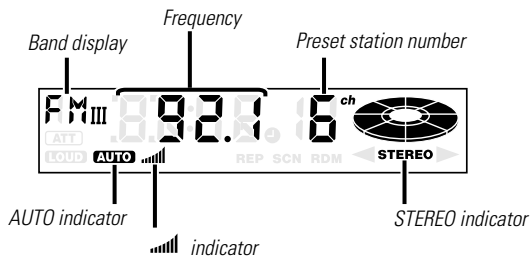
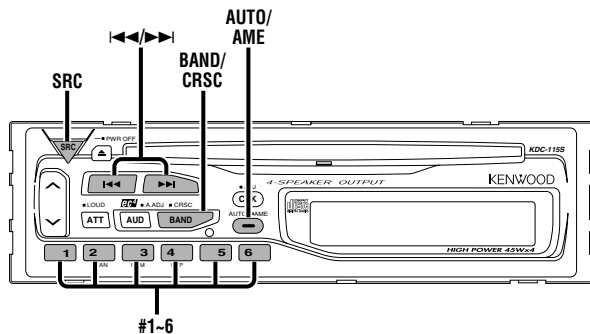

### Tuning

You can choose between auto seek tuning of receivable frequencies and manual tuning.

- 1 Press the SRC (source) button repeatedly to select the tuner mode. "TUnE" is displayed when the tuner mode has been selected.
- 2 Press the BAND button to select the band. Each time you press the BAND button, the band switches between FM1, FM2, FM3, and AM.
- 3 Press the AUTO button to switch between auto seek tuning and manual tuning. The AUTO indicator lights up only when auto seek tuning is selected.
- 4 • Auto Seek Tuning  
Press the ►► button to seek higher frequencies.  
Press the ◄◄ button to seek lower frequencies.  
• Manual Tuning  
Press the ►► button to increase the frequency by one step.  
Press the ◄◄ button to decrease the frequency by one step.

#### NOTE

The STEREO indicator lights up when stereo broadcasts are being received.

## Tuner features

### Station Preset Memory

Store the frequency of a station. You can then recall that station with a single touch of a button.

- 1 Select the band/ station that you want to have stored.
- 2 Press the button (#1-6) that you want to use for the station, for at least two seconds.  
The button number blinks once in the display to indicate that the data has been stored.

#### Recalling a Preset Station:

Press the preset station button (#1-6) for the desired station. The number of the recalled station is displayed.

#### NOTE

You can store six stations in each of the FM1, FM2, FM3, and AM bands.

### Auto Memory Entry

You can automatically store all the receivable frequencies in the band currently being listened to, and then recall them with the touch of a button later. This function is especially useful when you are travelling and do not know what stations are available. Up to six frequencies can be stored this way.

- 1 Select the band for auto memory entry.
- 2 Press the AME button for at least two seconds to start auto memory entry.  
The numbers of the preset station buttons are shown in order. When all the stations in a certain band are stored in the preset memory, the auto memory entry stops. The tuner then plays the last station received.

#### Recalling a Preset Station:

Press the preset station button (#1-6) for the desired station. The number of the recalled station is displayed.

### Clean Reception System Circuit (CRSC)

Temporarily have reception switched from stereo to mono to reduce multi-path noise when listening to the FM station. The factory default for this function is ON.

#### Turning CRSC On/Off:

Press the CRSC button for at least one second to turn the function on/off.

The  indicator lights up when CRSC is on.

#### NOTE

Strong electrical fields (such as from power lines) may cause unstable sound quality when CRSC is turned on. In such a situation, turn it off.

## CD player features

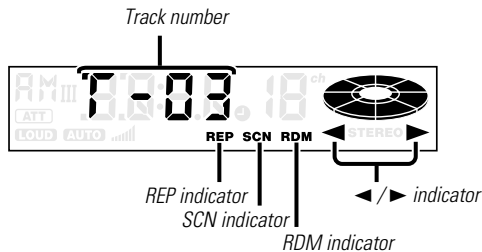
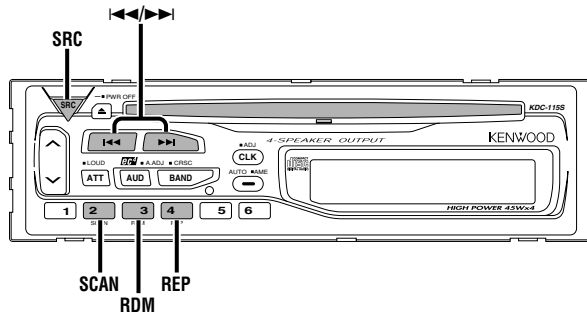

### Playing CDs

#### Playing CDs:

If no CDs are inserted, insert one in the slot with the label facing up.

If a CD is already inserted, press the SRC button repeatedly to select the CD mode.

"CD" is displayed when the CD mode has been selected.

The CD will start playing.

The ◀▶ indicator lights up when a CD has been inserted.

The ▶ indicator lights up when a CD is being played.

#### Stopping and Ejecting CDs:

Press the ▲ button.

The CD stops playing and ejects from the slot.

#### ▲CAUTION

- Do not attempt to insert a CD into the slot if another one is already there.
- The unit can only play 5 in. CDs. If you insert a 3 in. CD, it will get stuck inside and can cause the unit to malfunction.

#### NOTE

When you load a CD and eject it right away, the next time you try to insert the CD may not load. In such a situation, take the CD out for a moment and then reinsert it.

### Fast Forwarding and Reversing Disc Play

#### Fast Forwarding Disc Play:

Hold down on the ▶▶▶ button.

Release your finger to play the disc at that point.

#### Reversing Disc Play:

Hold down on the ◀◀◀ button.

Release your finger to play the disc at the point.

## CD player features

### Track Search

Search forward or backward through the tracks on the disc until you reach the one that you want to listen to.

#### **Making a Reverse Track Search:**

Press the ◀◀ button to display the desired track number.

Press once to search back to the beginning of the current track, twice to search back to the beginning of the previous track, and so forth.

Play starts at the beginning of the displayed track number.

#### **Making a Forward Track Search:**

Press the ▶▶ button to display the desired track number.

Press once to fast forward to the next track, twice to fast forward to the track after that, and so forth.

Play starts at the beginning of the displayed track number.

### Track Repeat

Repeat playing the track currently being listened to.

#### **Turning Repeat Play On/Off:**

Press the REP button to switch repeat play on and off.

The REP indicator lights up when repeat play is turned on.

The track number currently being heard blinks in the display.

#### **NOTE**

Repeat play is canceled when you eject the disc.

### Track Scan

Successively play the beginning of each track on a disc until you find the track that you want to listen to.

#### **Starting the Track Scan :**

Press the SCAN button. The SCN indicator lights up and the first 10 seconds of each track will be played, in order.

The track number currently being heard blinks in the display.

#### **Stopping to Listen to the Track Being Scanned:**

Press the SCAN button again to stop the scan and keep on listening to a track normally.

#### **NOTE**

The track scan function is canceled when you eject the disc.

### Random Play

Play all the tracks on the current disc in random order.

- 1 Press the RDM button to switch random play on and off. The RDM indicator lights up when random play is turned on. The track number will change over and over in the display as the next track is being selected. When the track has been selected, play will begin. The selected track number blinks in the display as it is being played.
- 2 To change the track being heard, press the ▶▶ button. Another track will be selected and played.





#### **NOTE**

Random play is canceled when you eject the disc.

## Accessories

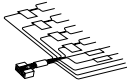
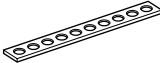
### External view

### Number of items

①		.....1
②		.....1
③		.....2
④		.....1
⑤		.....4
⑥		.....4

### ▲CAUTION

The use of any accessories except for those provided might result in damage to the unit. Make sure only to use the accessories shipped with the unit, as shown above.

## Installation Procedure

1. To prevent a short circuit, remove the key from the ignition and disconnect the ⊖ battery.
2. Make the proper input and output wire connections for each unit.
3. Connect the speaker wires of the wiring harness.
4. Connect the wiring harness wires in the following order: ground, battery, ignition.
5. Connect the wiring harness connector to the unit.
6. Install the unit in your car.
7. Reconnect the ⊖ battery.
8. Press the reset button.

### ▲CAUTION

- If your car's ignition does not have an ACC position, connect the ignition wires to a power source that can be turned on and off with the ignition key. If you connect the ignition wire to a power source with a constant voltage supply, as with battery wires, the battery may die.
- If the console has a lid, make sure to install the unit so that the faceplate will not hit the lid when closing and opening.
- If the fuse blows, first make sure the wires aren't touching to cause a short circuit, then replace the old fuse with one with the same rating.
- Do not let unconnected wires or terminals touch metal on the car or anything else conducting electricity. To prevent a short circuit, do not remove the caps on the ends of the unconnected wires or the terminals.
- Connect the speaker wires correctly to the terminals to which they correspond. The unit may be damaged or fail to work if you share the ⊖ wires or ground them to any metal part in the car.
- After the unit is installed, check whether the brake lamps, blinkers, wipers, etc. on the car are working properly.
- Insulate unconnected wires with vinyl tape or other similar material.
- Mount the unit so that the mounting angle is 30° or less.

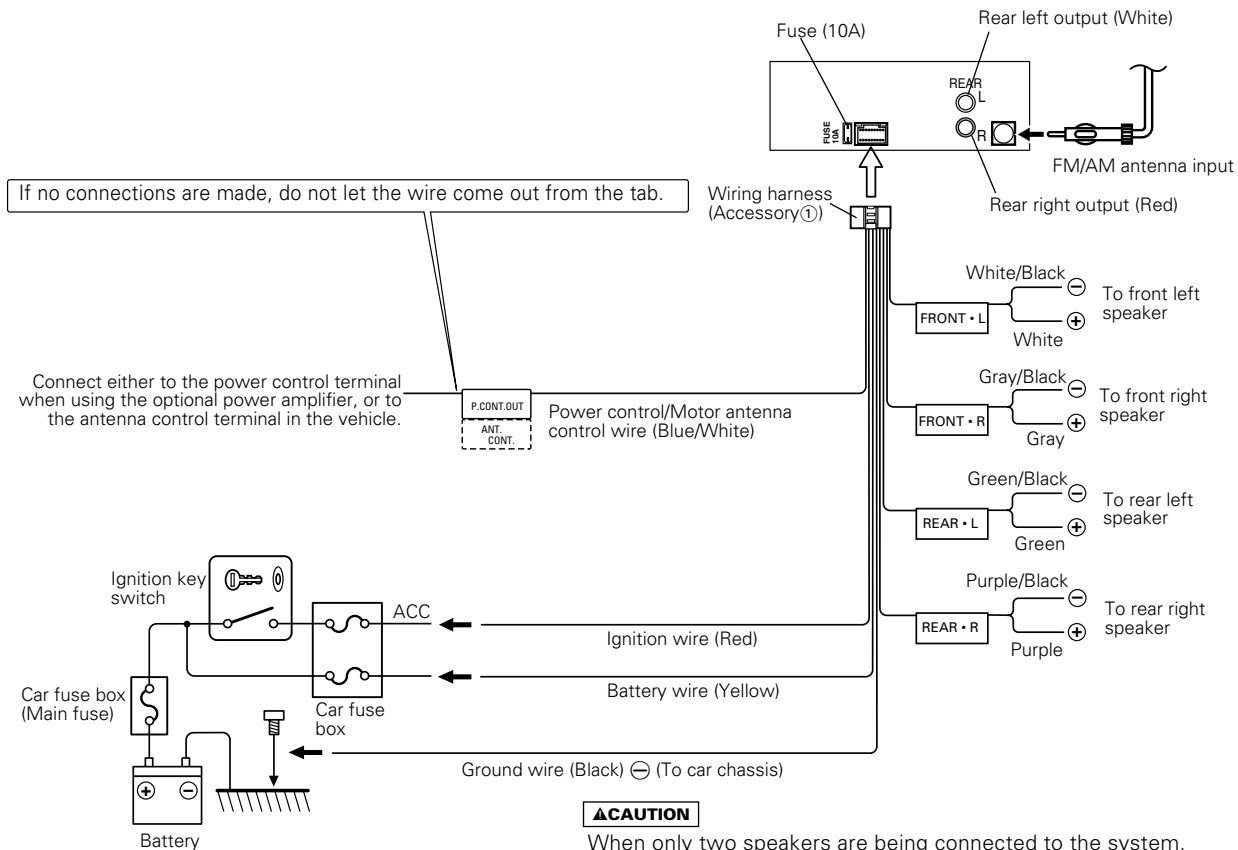

**⚠ WARNING**

If you connect the ignition wire (red) and the battery wire (yellow) to the car chassis (ground), you may cause a short circuit, that in turn may start a fire. Always connect those wires to the power source running through the fuse box.

**⚠ CAUTION**

When only two speakers are being connected to the system, connect the connectors either to both the front output terminals or to both the rear output terminals (do not mix front and rear). For example, if you connect the ⊕ connector of the left speaker to a front output terminal, do not connect the ⊖ connector to a rear output terminal.

# Installation

## ■ Installation

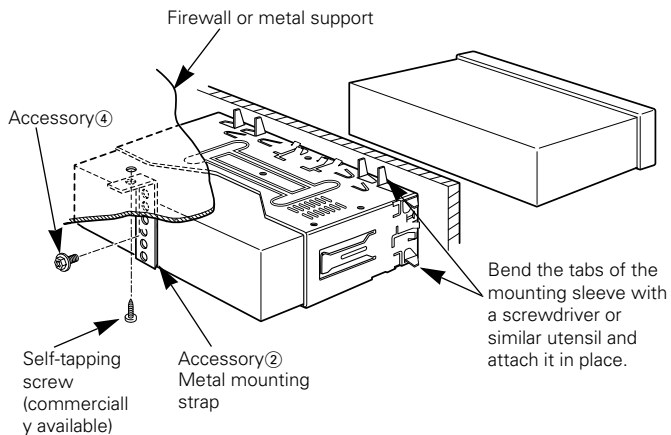

### NOTE

Make sure that the unit is installed securely in place. If the unit is unstable, it may malfunction (for example, the sound may skip).

## ■ Installing in Japanese-Made Cars

- 1 Refer to the section "Removing the hard rubber frame (P.16)" and then remove the hard rubber frame.
- 2 Align the holes in the unit (two locations on each side) with the vehicle mounting bracket and secure the unit with the accessory screws.

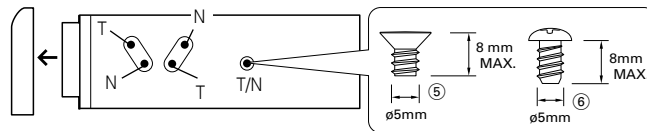

### CAUTION

- During installation, do not use any screws except for those provided. The use of different screws might result in damage to the main unit.
- Damage may occur if a screwdriver or similar tool is used with excessive force during the installations.

## Installation

### ■ Removing the hard rubber frame

- 1 Engage the catch pins on the removal tool and remove the two locks on the lower level.  
Lower the frame and pull it forward as shown in the figure.

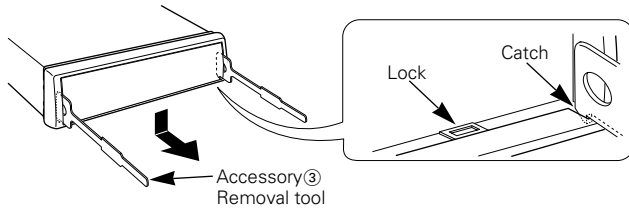

- 2 When the lower level is removed, remove the upper two locations.

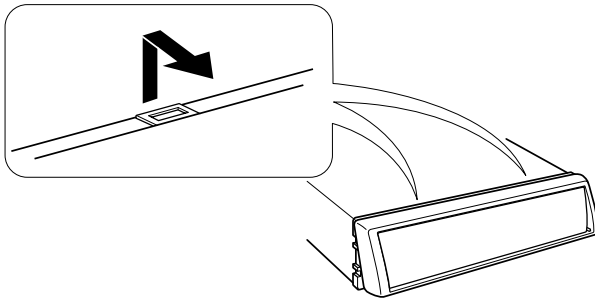

#### NOTE

The frame can be removed from the top side in the same manner.

### ■ Removing the Unit

- 1 Refer to the section "Removing the hard rubber frame (P.16)" and then remove the hard rubber frame.
- 2 Remove the Hex-head screw with integral washer (M4×8mm) on the back panel.
- 3 Insert the two removal tools deeply into the slots on each side, as shown.

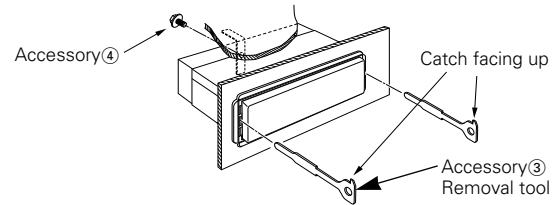

- 4 Lower the removal tool toward the bottom, and pull out the unit halfway whilst pressing towards the inside.

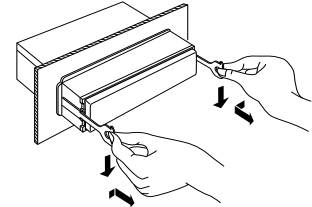

#### CAUTION

Be careful to avoid injury from the catch pins on the removal tool.

- 5 Pull the unit all the way out with your hands, being careful not to drop it.

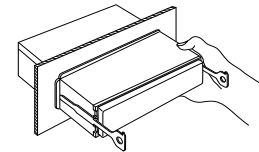



## Troubleshooting Guide

**What might seem to be a malfunction in your unit may just be the result of slight misoperation or miswiring. Before calling service, first check the following table for possible problems.**

PROBLEM	POSSIBLE CAUSE	SOLUTION
The power does not turn on.	The fuse has blown.	After checking for short circuits in the wires, replace the fuse with one with the same rating.
No sound can be heard, or the volume is low.	Attenuator is turned on.	Turn off Attenuator.
	The fader or balance settings are set all the way to one side.	Reset the fader or balance settings.
	The input/output wires or wiring harness are connected incorrectly.	Reconnect the input/output wires or the wiring harness correctly. See the section on "Connecting Wires to Terminals".
Nothing happens when the buttons are pressed.	The computer chip in the unit is not functioning normally.	Press the reset button on the unit (see p. 4).
The sound quality is poor or distorted.	One of the speaker wires is being pinched by a screw in the car.	Check the speaker wiring.
	The speakers are not wired correctly.	Reconnect the speaker wires so that each output terminal is connected to a different speaker.
Radio reception is poor.	The car antenna is not extended.	Pull the antenna out all the way.
	The antenna control wire is not connected.	Connect the wire correctly, referring to the section on "Connecting Wires to Terminals".
The memory is erased when the ignition is turned off.	The battery wire has not been connected to the proper terminal.	Connect the wire correctly, referring to the section on "Connecting Wires to Terminals".
	The ignition and battery wire are incorrectly connected.	Connect the wire correctly, referring to the section on "Connecting Wires to Terminals".
A CD ejects as soon as it is loaded.	The CD is upside-down.	Load the CD with the labeled side up.
	The CD is quite dirty.	Clean the CD, referring to the section on "Cleaning CDs" (see p. 5).
The sound skips on a CD.	The CD is scratched or dirty.	Clean the CD, referring to the section on "Cleaning CDs" (see p. 5).
	The mounting angle exceeds 30°.	Adjust to an angle of less than 30°.
A track will not play.	Random play has been selected.	Turn off random play.

## Troubleshooting Guide

The following messages are displayed when certain problems are occurring in your system. Take the recommended actions.

- E-99      Something is wrong with the disc magazine. Or the unit is malfunctioning for some reason.  
⇒ Check the disc magazine. And then press the reset button on the unit. If the "E- 99" code does not disappear, consult your nearest service center.
- HOLd      The protective circuit in the unit activates when the temperature inside the automatic disc changer exceeds 60°C (140°F), stopping all operation.  
⇒ Cool down the unit by opening the windows or turning on the air conditioner. As the temperature falls below 60°C (140°F), the disc will start playing again.

## Specifications

### Specifications subject to change without notice.

#### **FM tuner section**

Frequency range (200 kHz space) .....	87.9 MHz – 107.9 MHz
Usable sensitivity (S/N = 30dB).....	9.3dBf (0.8 $\mu$ V/75 $\Omega$ )
Quieting Sensitivity (S/N = 50dB).....	15.2dBf (1.6 $\mu$ V/75 $\Omega$ )
Frequency response ( $\pm$ 3.0 dB) .....	30 Hz – 15 kHz
Signal to Noise ratio (MONO) .....	70 dB
Selectivity ( $\pm$ 400 kHz) .....	$\geq$ 80 dB
Stereo separation (1 kHz).....	40 dB

#### **AM tuner section**

Frequency range (10 kHz space) .....	530 kHz – 1700 kHz
Usable sensitivity (S/N = 20dB) .....	28 dB $\mu$ (25 $\mu$ V)

#### **CD player section**

Laser diode .....	GaAlAs ( $\lambda$ =780 nm)
Digital filter (D/A) .....	8 Times Over Sampling
D/A Converter .....	1 Bit
Spindle speed .....	500 – 200 rpm (CLV)
Wow & Flutter .....	Below Measurable Limit
Frequency response ( $\pm$ 1 dB) .....	10 Hz – 20 kHz
Total harmonic distortion (1 kHz) .....	0.01 %
Signal to Noise ratio .....	96 dB (1 kHz)
Dynamic range .....	93 dB
Channel separation .....	85 dB

#### **Audio section**

Maximum output power .....	45 W $\times$ 4
Full bandwidth power (at less than 1% THD).....	22 W $\times$ 4
Tone action	
Bass: .....	100 Hz $\pm$ 10 dB
Treble: .....	10 kHz $\pm$ 10 dB
Preout level / Load.....	1800mV/10k $\Omega$
Preout impedance .....	$\leq$ 600 $\Omega$

#### **General**

Operating voltage .....	14.4 V (11 – 16 V allowable)
Current consumption .....	10 A
Installation size (W $\times$ H $\times$ D) .....	182 $\times$ 53 $\times$ 160 mm
	7-3/16 $\times$ 2-1/16 $\times$ 6-5/16 in.
Weight.....	3.1 Lbs (1.4 kg)

## Content

	Page
U.S.A.	2
Australia	3
Canada	4
Military	6
Belgique et Grand-duché de Luxembourg	8
Danmark	9
Deutschland	9
Nederland	10
Portugal	10
U.K. & Ireland	11
Österreich	11
Ellás	12
España	12
France	13
Italia	13
Suomi	14
Andorra	14
Iceland	14
Malta	14
Norge	15
Schweiz	15
Svizzera	15
Suisse	15
Sverige	15

Dear Customer,

Thank you for purchasing the Product. As mentioned on this page of this booklet, our Warranty is only valid in the countries listed. If your country is not listed please contact your retailer for information on warranty procedure or write to:

KENWOOD Customer Information Center  
3-17-9 Aobadai  
Meguro-ku Tokyo 153-0042 JAPAN  
Kenwood Corporation  
Customer Information Center

# KENWOOD

## Warranty Card

Geräte-Typ und Seriennummer  
Identification du produit  
Produkt navn og serie nummer  
Modelo y Número de serie  
Malli ja sarjanumero  
Μοντέλο και αριθμός σειράς  
Modello e numero di matricola  
Modell og serienummer  
Modelo e numero de serie  
Apparat typ & serienummer  
Identificatie van het produkt  
Módel heiti og raðnumber  
Il-Mudell u s-serial number  
Model name & serial number

Stempel und Unterschrift des Händlers  
Revendeur & cachet  
Forhandler  
Distribuidor y sello  
Jälleenmyyjä & leima  
Σφραγίδα εταιρίας  
Timbro del rivenditore  
Forhandlerens navn og stempel  
Agente e carimbo  
Aterförsäljare & stämpel  
Dealer & stempel  
Undirritun og stimpill söluaðila  
Timbru tal-beijjegh  
Dealer & stamp

Kaufdatum  
Date d'achat  
Købsdato  
Fecha de compra  
Ostopäivä  
Ημερομηνία αγοράς  
Data di acquisto  
Kjøpt dato  
Data de compra  
Inköpsdatum  
Aankoopdatum  
Söludagur  
Id-data ta' meta nxtara  
Purchase date

Name und Anschrift des Käufers  
Nom & adresse du client  
Købers navn og adresse  
Nombre y dirección del cliente  
Asiakkaan nimi & osoite  
Όνομα και διεύθυνση αγοραστή  
Nome e indirizzo del cliente  
Kundens navn og adresse  
Nome e morada do comprador  
Kundens namn & adress  
Naam & adres van de klant  
Nafn og heimilisfang kaupanda  
L-ismen u l-indirzz tax-xerrej  
Name & address of customer

The tables of content are a back cover

This warranty will be honored only in the U.S.A.

## **KENWOOD LIMITED WARRANTY FOR CAR STEREO COMPONENTS**

### **HOW LONG IS THE WARRANTY**

Kenwood U.S.A. Corporation ("Kenwood") warrants this product for a period of one (1) year from the date of original purchase.

### **WHAT IS COVERED AND WHAT IS NOT COVERED**

Except as specified below, this warranty covers all defects in material and workmanship in Kenwood car stereo components. The following are not covered by the warranty:

1. Any product which is not distributed in the U.S.A. by Kenwood or which is not purchased in the U.S.A. from an authorized Kenwood car stereo dealer or an automobile dealer, unless the product is purchased through the U.S.A. Military Exchange Service.
2. Any product on which the serial number has been defaced, modified or removed.
3. Damage, deterioration or malfunction resulting from:
  - a. Any shipment of the product (claims must be presented to the carrier).
  - b. Installation or removal of the product.
  - c. Accident, acts of nature, misuse, abuse, neglect, unauthorized product modification or failure to follow instructions supplied with the product.
  - d. Repair or attempted repair by anyone not authorized by Kenwood.
  - e. Any other cause which does not relate to a product defect.

### **WHO IS PROTECTED**

This warranty is enforceable only by the original purchaser.

### **WHAT WE WILL PAY FOR**

We will pay for all labor and material expenses for covered items. Payment of shipping charges is discussed in the next section of this warranty.

### **HOW TO OBTAIN WARRANTY SERVICE**

If your KENWOOD product ever needs service:

1. Take or ship it to any KENWOOD Authorized Service Center in the U.S.A. along with a complete description of the problem. (If you are uncertain as to whether a Service Center is authorized, please call **1-800-KENWOOD** for the nearest Service Center. **1-800-536-9663**).
2. Although you must pay any shipping charges if it is necessary to ship the product for warranty service, we will pay the return shipping charges if the repairs are covered by the warranty within the United States.
3. Whenever your units are taken or sent for warranty service, you must include a copy of the original dated sales receipt as proof of warranty coverage.

### **LIMITATION OF IMPLIED WARRANTIES**

ALL IMPLIED WARRANTIES, INCLUDING WARRANTIES OF MERCHANTABILITY AND FITNESS FOR A PARTICULAR PURPOSE, ARE LIMITED IN DURATION TO THE LENGTH OF THIS WARRANTY.

### **EXCLUSION OF DAMAGES**

KENWOOD'S LIABILITY FOR ANY DEFECTIVE PRODUCT IS LIMITED TO THE REPAIR OR REPLACEMENT OF THE PRODUCT AT OUR OPTION. KENWOOD SHALL NOT BE LIABLE FOR:

1. INSTALLATION OR REMOVAL CHARGES, DAMAGE TO OTHER PROPERTY CAUSED BY ANY DEFECTS IN KENWOOD CAR STEREO COMPONENTS, DAMAGES BASED UPON INCONVENIENCE, LOSS OF USE OF THE PRODUCT; OR
2. ANY OTHER DAMAGES, WHETHER INCIDENTAL, CONSEQUENTIAL OR OTHERWISE.

SOME STATES DO NOT ALLOW LIMITATIONS ON HOW LONG AN IMPLIED WARRANTY LASTS AND/OR DO NOT ALLOW THE EXCLUSION OR LIMITATION OF INCIDENTAL OR CONSEQUENTIAL DAMAGES, SO THE ABOVE LIMITATIONS AND EXCLUSIONS MAY NOT APPLY TO YOU.

This warranty gives you specific legal rights, and you may also have other rights which vary from state to state.

If a problem develops during or after the Limited Warranty Period, or if you have any questions regarding the operation of the product, you should contact your KENWOOD Authorized Dealer or Authorized Service Center. If the problem or your question is not handled to your satisfaction, please contact our Customer Relations Department at the address listed below:

**KENWOOD SERVICE CORPORATION**  
P.O. Box 22745, 2201 East Dominguez Street, Long Beach CA 90801-5745  
Tel: (310) 639-5300